

# SECTION 4.2\_KSES

## EMERGENCY RELIEF VALVE PRESSURE RELIEF

### INTRODUCTION

**The model KSES** is designed to provide emergency pressure relief for storage tanks when exposed to overpressures that are not handled by standard tank vents. These vents provide the capacity to meet API standard 2000 for emergency venting due to fire exposure when properly sized.

### Setting Pressure

KSES Permanent Setting	Min. 700 mmW.C ~ Max. 9,500 mmW.C
------------------------	-----------------------------------

**Body Materials** Aluminium, Carbon Steel, SS304 and SS316 with various trims  
(Different materials available on request)

**Sizes range** DN 400, 450, 500 and DN 750 with ASME 150Lb or API 650 flanges  
(Different connections available on request)

**Rules & Certifications** API 2000 & KFI

**Optimum / optional Design & Arrangements** Stem Jacket type, Steam Tracing type, Proximity type, Teflon Coating/Lining type

### APPLICATION

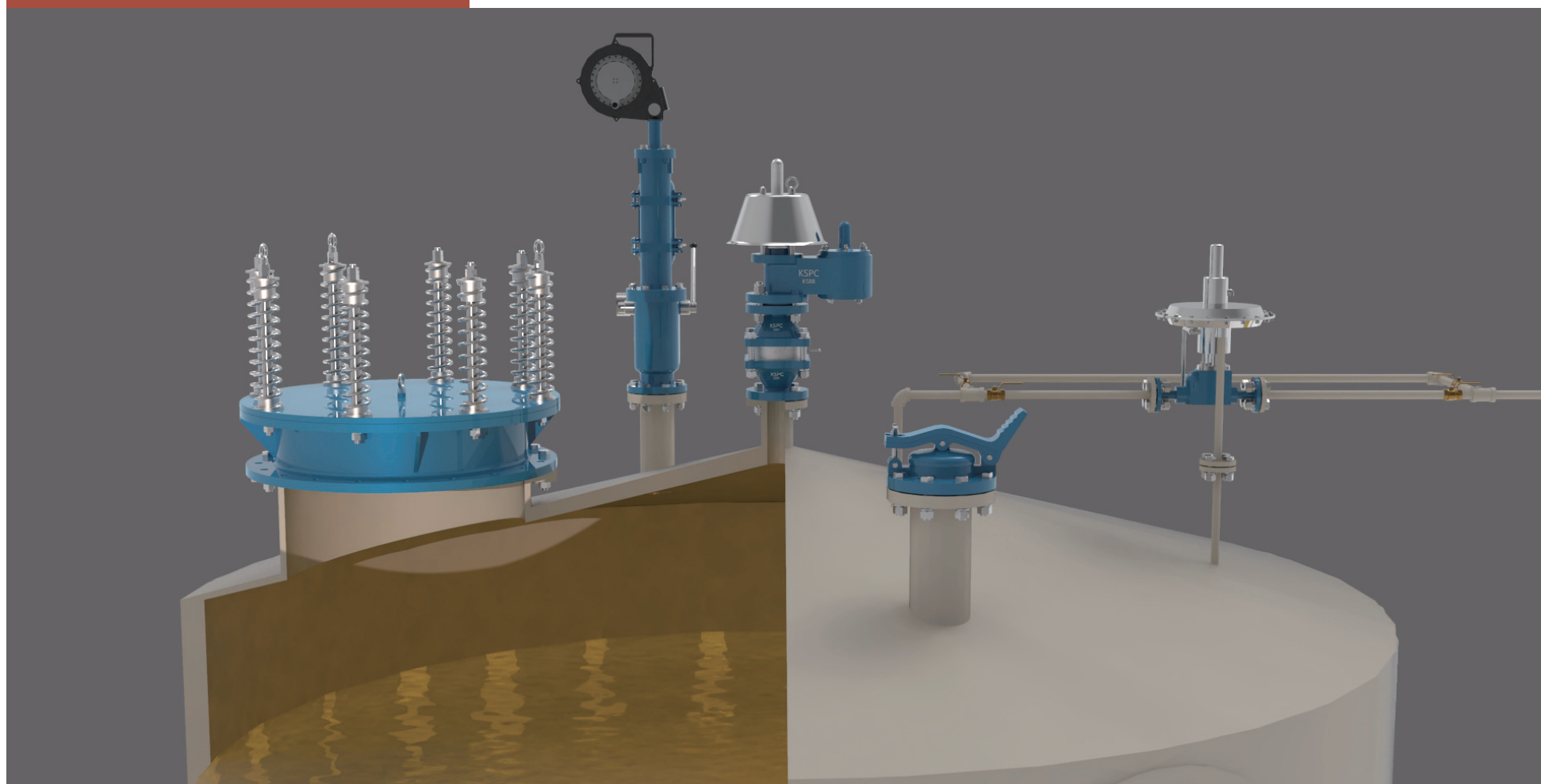

## OUTLINE DRAWING

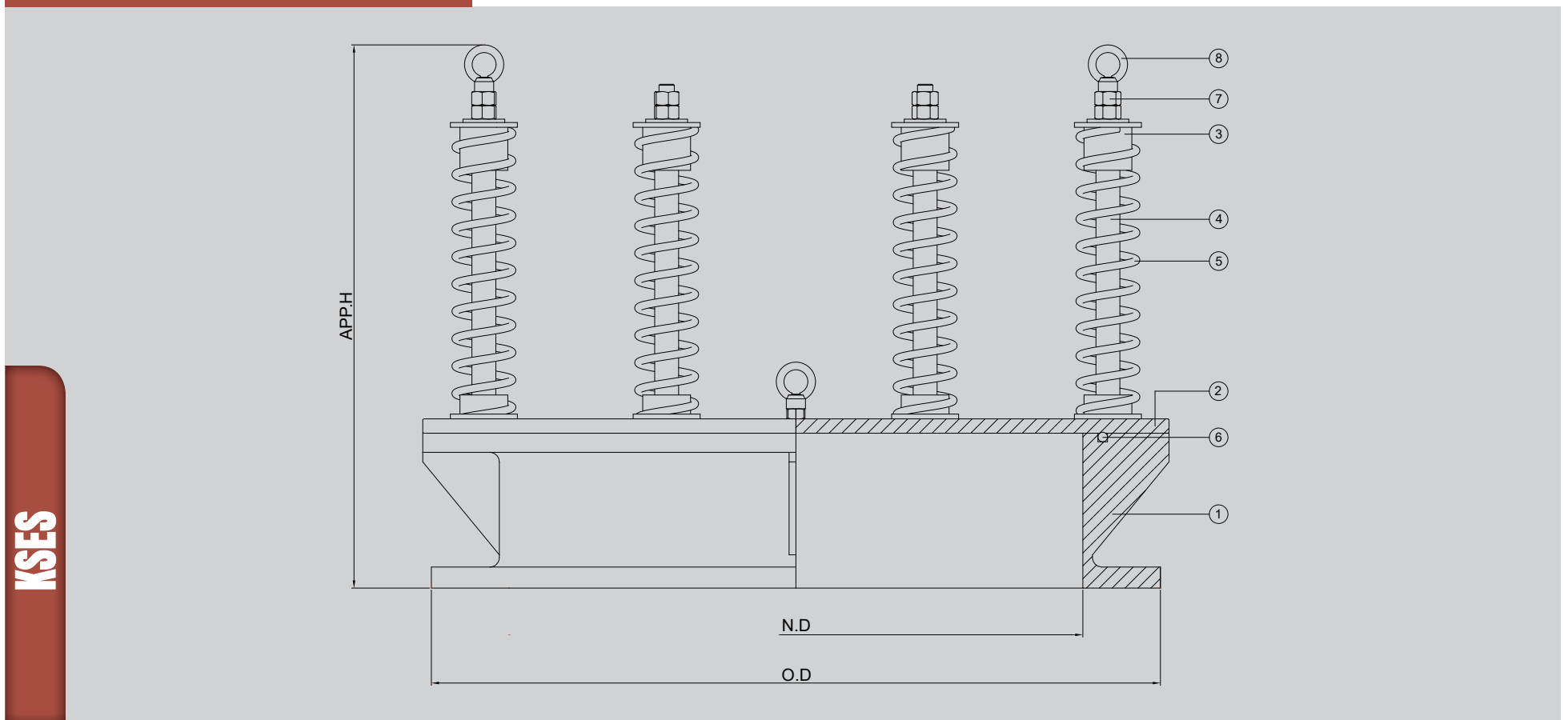

## DIMENSION TABLE

SIZE		16"	18"	20"	24"
N.D		400	450	500	600
O.D	API 650	-	-	650/660	750/762
	ASME 150#	595	635	700	815
Approx. H	MIN.	530	530	530	530
	MAX.	590	590	590	590

**NOTE** CERTIFIED DIMENSIONS AVAILABLE UPON REQUEST (STD : API650).

## COMPONENT MATERIAL

ITEM NO	COMPONENT	BODY	ALUMINIUM	CARBON STEEL	SS304	SS316
		TRIM	SS304	SS304	SS304	SS316/SS316L
1	BODY		B26-319.F	A216-WCB	A351-CF8	A351-CF8M
2	COVER(DISC)		CARBON STEEL	CARBON STEEL	SS304	SS316L
3	SPRING PAD		SS304	SS304	SS304	SS316
4	SPRING STEM		SS304	SS304	SS304	SS316
5	SPRING		SS304	SS304	SS304	SS316
6	O-RING		VITON or REQUIRED			
7	HEX. NUT		SS304	SS304	SS304	SS316
8	LIFTING EYE NUT		SS304	SS304	SS304	SS316